

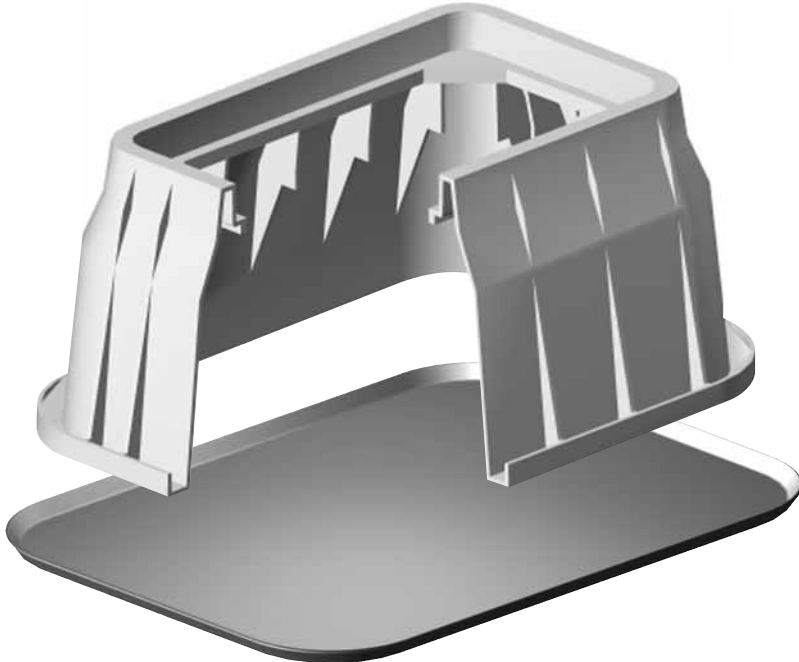

Medium Box Series 1324

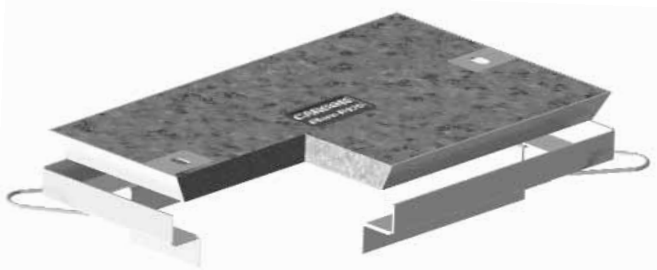
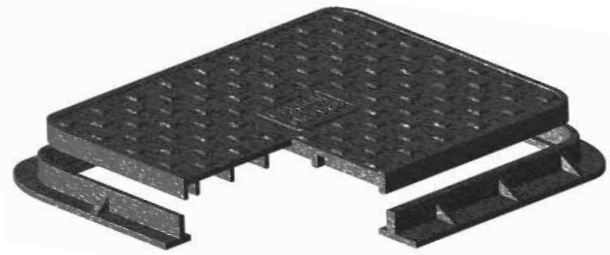
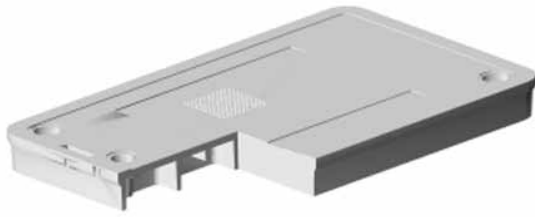

Cover Options

See reverse for details of various cover and frame options.

Box Options

Product **Box**
1324-15B (with Insert)

Dimensions:

Inside	Outside	
L/W 600/355	A/B 645/400	D 390
X/Y 760/575	E/F 835/590	

Product **Box**
1324-18 (not shown)

Dimensions:

Inside	Outside	
L/W 565/325	A/B 630/390	D 455
X/Y 790/540	E/F 860/620	

Product **Base Extension**
1324-8 (not shown)

L/W 790/540	A/B 860/620	D 205
-------------	-------------	-------

Bottom Plates/Floors

See reverse for details of bottom plates/floors and grate options.

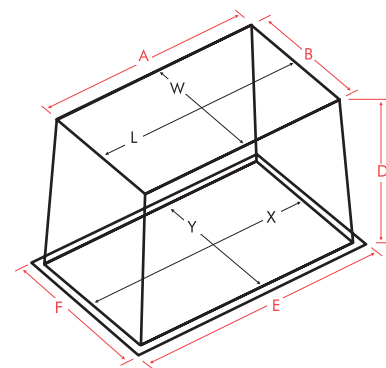

Application Notes: Carson boxes are suitable for a wide range of applications, from grass verge (A15) to car park & footpath applications (B125). It is important to select the correct cover and frame and installation method to suit the loading and local conditions. Technical advice is available from Carson. These products are not designed for carriageway use. *All dimensions to nearest 5mm.* Due to our policy of continuous improvement, we reserve the right to change specifications without notice.



IDA Business & Technology Park,
Racecourse Road, Roscommon, Ireland.
Tel: +353 (0)9066 25922
Fax: +353 (0)9066 25921
email: sales@carson europe.com

www.carson europe.com www.multiduc.com



Glendora, California

www.carsonind.com



Medium Box Series 1324

Material Data

(Specification available on request)

Structural Foam - High Density Polyethylene

HDPE has excellent chemical resistance to ethanol, acetone, diesel etc. and is unaffected by sulfate ground conditions.

- Recyclable
- Robust - no breakage waste
- Completely impervious to water
- Nitrogen injection creates cellular core (CFC free)
- High strength to weight ratio
- High stiffness to weight ratio
- Easy to cut for duct entries

Properties of unfoamed resin	Test Method	HDPE
Tensile Strength	ISO 1926	21.37 - 37.92 N/mm ²
Flexural Modulus	ISO 1290 - 2	1103 - 1447 N/mm ²
Notched Izod Impact Strength	ISO 180 - 1A	270 - 800 J/M
Deflection Temperature	ISO 75 - 1	73 - 82°
Density	ISO 8962	0.955 g/cm ³
Chemical Resistance	-	Excellent
Water Absorption	-	None

Vertical Load Rating

When installed, meets the loading requirements of EN124 Class B125 i.e. 125kN (~12.5T) test load. Suitable for areas accessible to all slow moving traffic.



Other Depth Options

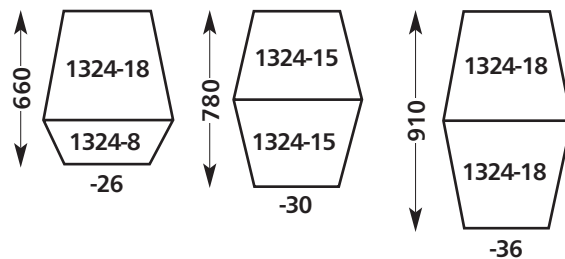

Cover and Frame Options

- HDPE (A15)
- Galvanised Steel T Cover
- Concrete Infill Cover & Galvanised Steel Frame (EN124 Class B125)
- Ductile Iron Cover & Frame (EN124 Class B125)

Other options available on request.

Base Options

- Duct and pipe entries can be provided to suit customer applications
- Bottom plates/floors and grates to protect or locate internal equipment can be provided.

Standard Shipping Configuration

	1324-15B	1324-18
#/pallet	26	28
L	1220	1220
W	825	825
H	2670	2415

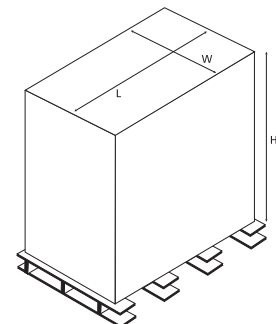

(The configuration shown can change to optimise transport utilisation.)

Application Notes: Carson boxes are suitable for a wide range of applications, from grass verge (A15) to car park & footpath applications (B125). It is important to select the correct cover and frame and installation method to suit the loading and local conditions. Technical advice is available from Carson. These products are not designed for carriageway use. All dimensions to nearest 5mm. Due to our policy of continuous improvement, we reserve the right to change specifications without notice.



IDA Business & Technology Park,
Racecourse Road, Roscommon, Ireland.
Tel: +353 (0)9066 25922
Fax: +353 (0)9066 25921
email: sales@carson europe.com
www.carson europe.com www.multiduc.com



www.carsonind.com